

IS119

User Manual

# IS119 User Manual

Version 1.0

- Distribution Date: June 1st, 2017
- Copyright 2017 by Adamson Systems Engineering Inc.; all rights reserved

This manual must be accessible to the person operating this product. As such, the product owner must store it in a safe place and make it available upon request to any operator.

Resale of this product must include a copy of this manual.

If this manual becomes damaged or additional copies are needed, please email [support@adamsonsystems.com](mailto:support@adamsonsystems.com).

## Declarations

### CE Declaration of Conformity

ADAMSON SYSTEMS ENGINEERING, Inc.  
1401 Scugog Line 6, Port Perry (ON), L9L 1B2, Ontario,  
Canada

T: +1 905 982 0520, F: +1 905 982 0609

Email: [info@adamsonsystems.com](mailto:info@adamsonsystems.com)

Website: [www.adamsonsystems.com](http://www.adamsonsystems.com)

Adamson Systems Engineering declares that the products stated below are in conformance with the relevant fundamental health and safety criteria of the applicable EC Directive(s), in particular:

#### Directive 2006/95/EC: Low Voltage Directive

994-0005 IS119  
994-0006 IS119b  
973-0006 IS10  
973-0007 IS10b

#### Directive 2006/42/EC: Machinery Directive

930-0028 IS10 & IS119 Support Frame  
930-0021 S-Series Extended Beam  
930-0022 S-Series Moving Point Extended Beam  
930-0030 IS10 Micro Frame  
932-0037 H-Clamp



Established at Port Perry, ON, CA - June 1st, 2017

-----  
Brock Adamson (President & CEO)

**ADAMSON**  
IS-Series

# Table of Contents

1.	Safety & Warnings	3
2.	Product Introduction	4
3.	Wiring & Amplification	5
4.	Presets & Control	7
5.	Acoustic Data	8

## Safety & Warnings

### Safety & Warnings

- Read these instructions, keep them available for reference. They can be downloaded any time from <https://www.adamsonsystems.com/en/support/downloads-directory/is-series/is119> Heed all warnings and follow all instructions.
- A qualified technician must be present during the installation and use of this product. This product is capable of producing extremely high sound pressure levels and should be used according to the specified local sound level regulations and good judgement. Adamson Systems Engineering will not be liable for damages caused by any possible misuse of this product.
- Servicing is required when the loudspeaker has been damaged in any way, such as when the loudspeaker has been dropped; or when for undetermined reasons the loudspeaker does not operate normally.
- Protect the cabling from being walked on or pinched.
- Read the IS-Series Rigging Manual before installing the IS119.
- Pay attention to rigging instructions included in both Blueprint AV™ and the IS-Series Rigging Manual.
- Use only with the rigging frames/accessories specified by Adamson, or sold with the loudspeaker system.
- This speaker enclosure is capable of creating a strong magnetic field. Please use caution around the enclosure with data storage devices such as hard drives.

# Product Introduction

## IS119 Sub Compact Subwoofer

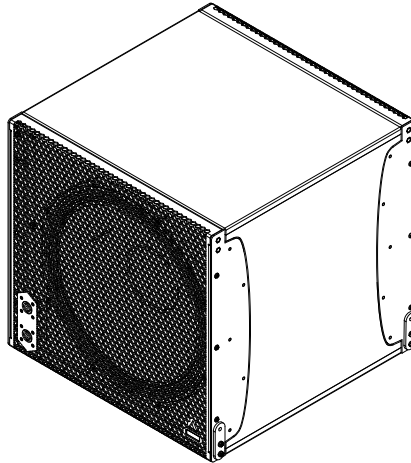

- The IS119 is a sub compact subwoofer enclosure designed for extended LF capabilities. It has an unobtrusive visual design which blends seamlessly into the surrounding space. It contains one ND19-S 19" LF driver.
- Up to 16 IS119 can be flown when using the IS10 & IS119 Support Frame.
- The IS119 can be flown in the same array as the IS10 when using an additional IS10 & IS119 Support Frame.
- Adamson's use of proprietary technologies such as Advanced Cone Architecture give the IS119 an extremely high maximum SPL level of 138 dB. The nominal impedance of the IS119 is 8  $\Omega$ .
- The operational frequency range of the IS119 is 30 Hz to 80 Hz, +/- 3 dB.
- The IS119 is intended to be paired with the IS10 Sub Compact Line Array with a crossover frequency range of approximately 80 Hz.
- The wooden enclosure is made of marine grade birch plywood, and has an aluminum rigging system mounted on each corner. Without sacrificing lowered resonance to composite material, the IS119 is able to maintain a low weight of 44.5 kg / 98 lbs.
- The IS119 is designed for use with Lab.gruppen's D-Series line of installation amplifiers.

In an effort to continuously improve its products, Adamson releases updated accompanying software, presets and standards for its products. **Adamson reserves the right to change the specifications of its products and the content of its documents without prior notice.**

# Wiring & Amplification

## Wiring

The **IS119** (994-0005) comes with 4x Neutrik Speakon™ NL4 connections, wired in parallel. The 2 rear connections pass pin 1 +/- to the driver and the 2 front connections pass pin 2 +/- to the driver.

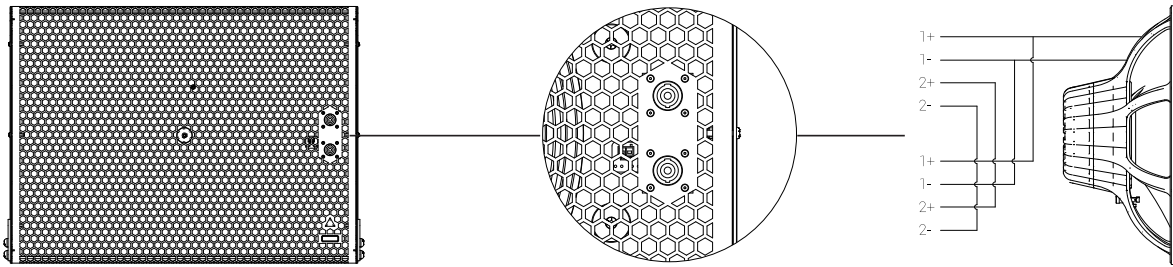

IS119 Rear

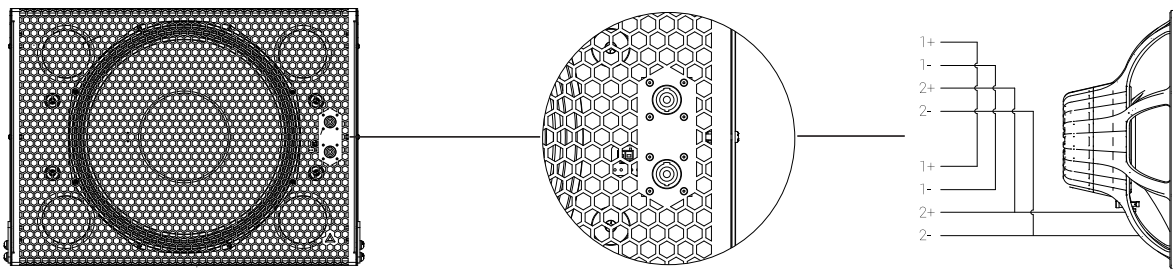

IS119 Front

The **IS119b** (994-0006) comes with an external barrier strip mounted to the rear grill. Terminals 1, +/- are passed to the driver, terminal 2, +/- are not connected.

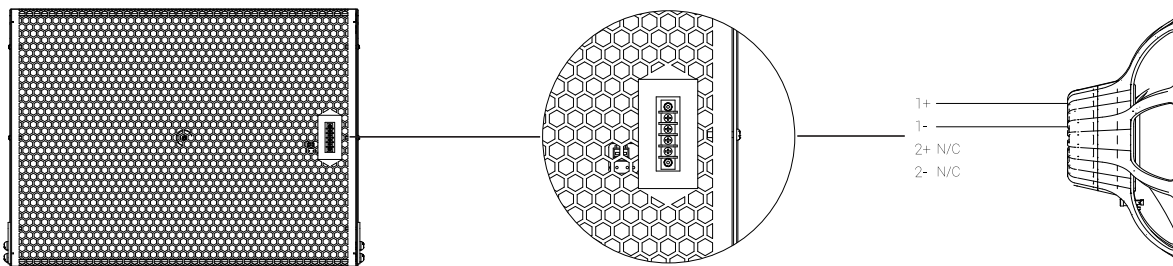

IS119b Rear

To operate the IS119b in FB or FBF cardioid mode, swap the front and rear grills by:

1. Removing the six screws holding each grill to the side rigging pieces
2. Unclipping the grill with the barrier strip from the rear PCB, and swapping the grills
3. Re-clipping the grill with the barrier strip to the front PCB and affix with the same screws

# Wiring & Amplification

## Amplification

The IS119 is paired with Lab.gruppen **D-Series** amplifiers. Maximum quantities of the IS119 per amplifier model are shown below. For a master list, please refer to the Adamson PLM & Lake Handbook, found on our website.

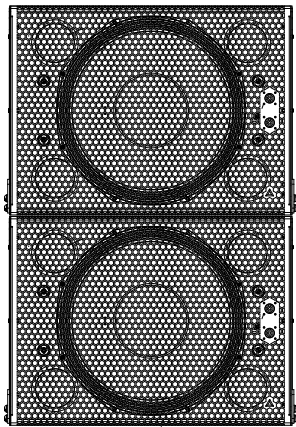

2x IS119

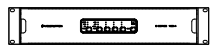

D80:4L

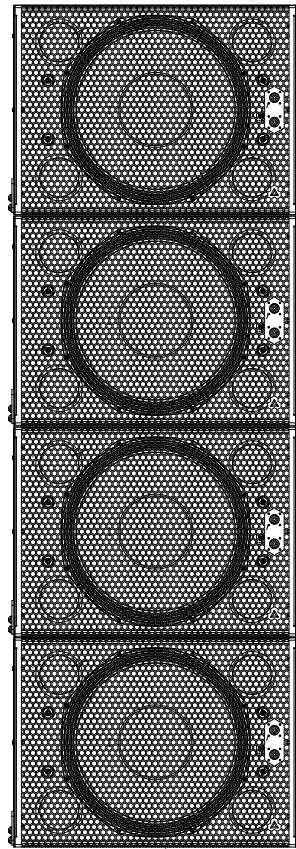

4x IS119

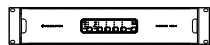

D120:4L

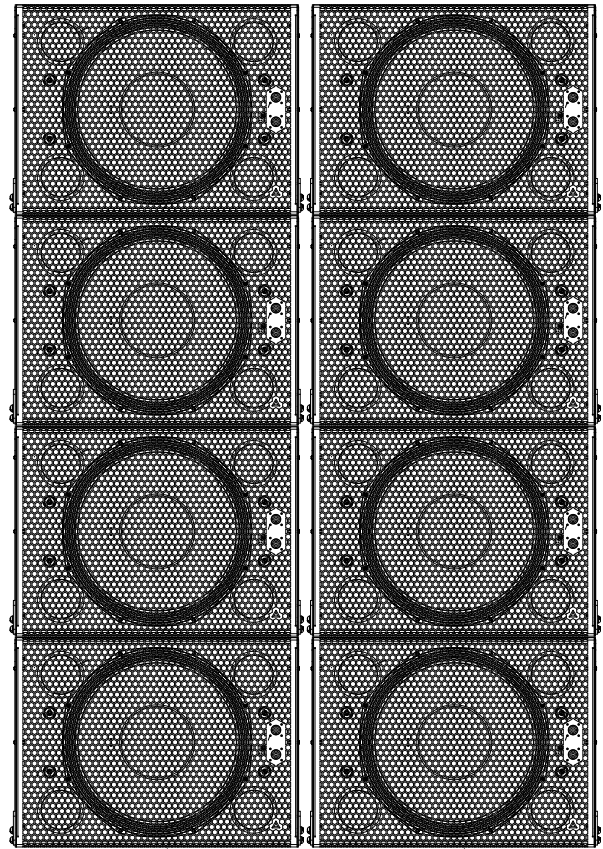

8x IS119

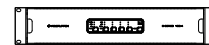

D200:4L

## LoadSmart™

Use LoadSmart™ verification to ensure that all connections are made properly. On the D-Series line of amplifiers, LoadSmart™ can be accessed through Lake Controller. Please refer to the Adamson Lake & PLM Handbook, which is included in the Adamson LoadLibrary, which can be found on the [Adamson Website](#).

# Presets & Control

## Presets

The Adamson LoadLibrary contains presets designed for 3 different IS119 deployments. Furthermore, there are presets designed to pair with either the IS7 or the IS10. The below preset descriptions pertain to the standalone subwoofer presets. For a master list, please refer the Adamson PLM & Lake Handbook, found on our website.

### Subwoofer Configuration

### Applicable Preset

### Subwoofer Configuration

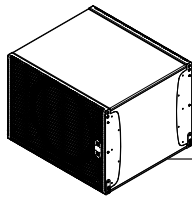

**IS119 32dB**  
*All IS119 forward facing*  
  
*Omni pattern*

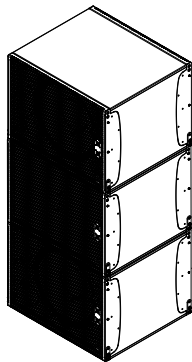

**IS119 FB 32dB**  
*Bottom IS119 forward facing, top IS119 reversed*  
  
*Cardioid pattern*

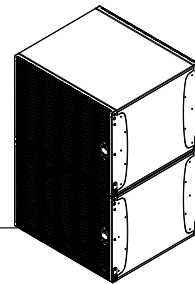

**IS119 FBF 32dB**  
*Bottom and top IS119 forward facing, middle IS119 reversed*  
  
*Cardioid pattern*

**IS119 EF66 32dB**  
*Two IS119 stacks, distance from front grill to front grill of 66" (1.7m)*

*Cardioid pattern*

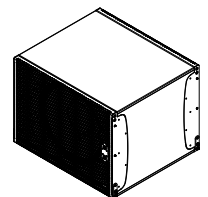
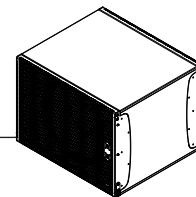

## Alignment

When flown or stacked in the same array as an IS10, all IS119 presets contain the inherent delay needed to be properly phase-aligned. When flown separately or ground stacked, IS119 subs should be phase-aligned to the IS10 array using measurement software.

# Acoustic Data

## Cardioid Dispersion

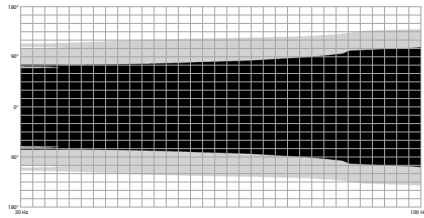

IS119 FB

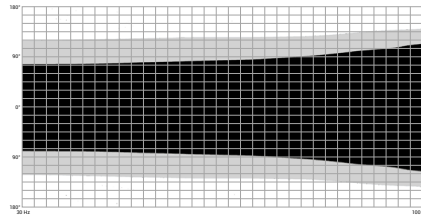

IS119 FBF

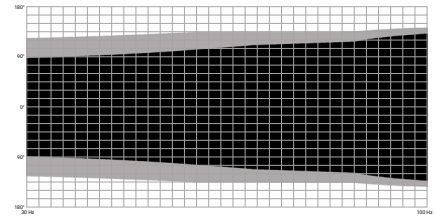

IS119 EF66

## Technical Specifications

Frequency Range (+/- 3dB)	30 Hz - 80 Hz
Maximum Peak SPL **	138 dB
Components LF	ND19 19" Kevlar Neodymium Driver
Nominal Impedance LF	8 Ω
Power Handling (AES / Peak) LF	1200 / 4800 W
Rigging	Integrated Rigging System
Connection	4x Speakon™ NL4 (2x Front 1+/-, 2x Rear (2+/-), or Barrier Strips
Height Front (mm / in)	544 / 21.4
Width (mm / in)	737 / 29
Depth (mm / in)	645 / 25.4
Weight (kg / lbs)	44.5 / 98
Colour	Black & White (Standard), RAL Colours (On Demand)
Processing	Lake

\*\*12 dB crest factor pink noise at 1m, half space, using specified processing and amplification

